

## Notch Style Threading &amp; Grooving Tool Holders

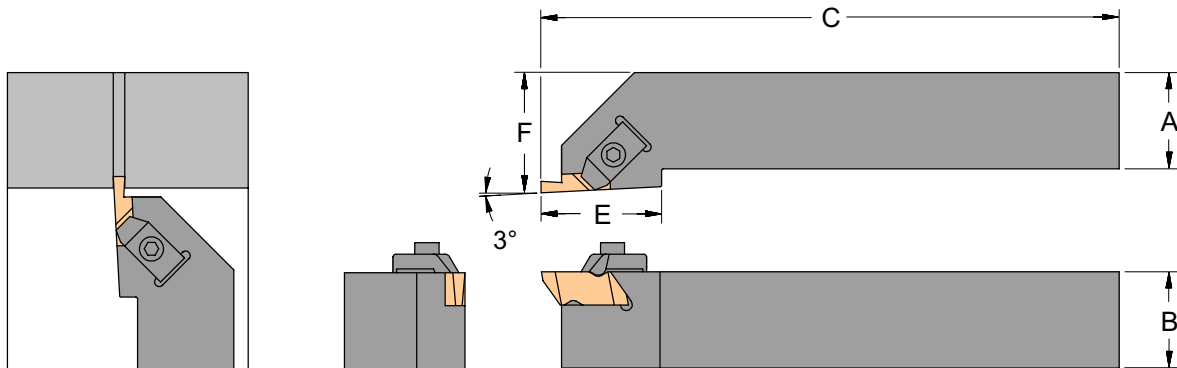

Right Hand Shown

Holder Description		Dimensions						Parts	
Right Hand	Left Hand	Insert Size Grooving - Threading	A	B	C	E	F	Clamp	Screw
TSR-62		HG 2xxxR - HT 2R	.375	.375	2.500	.750	.562	CM-74	S-310
	TSL-62	HG 2xxxL - HT 2L						CM-75	
TSR-82		HG 2xxxR - HT 2R	.500	.500	3.500	.750	.750	CM-74	S-310
	TSL-82	HG 2xxxL - HT 2L						CM-75	
TSR-102B		HG 2xxxR - HT 2R	.625	.625	4.500	.750	.875	CM-74	S-310
	TSL-102B	HG 2xxxL - HT 2L						CM-75	
TSR-122B		HG 2xxxR - HT 2R	.750	.750	4.500	.750	1.000	CM-74	S-310
	TSL-122B	HG 2xxxL - HT 2L						CM-75	
TSR-162C		HG 2xxxR - HT 2R	1.000	1.000	5.000	.750	1.250	CM-74	S-310
	TSL-162C	HG 2xxxL - HT 2L						CM-75	
TSR-123B		HG 3xxxR - HT 3R	.750	.750	4.500	1.250	1.000	CM-72	S-412
	TSL-123B	HG 3xxxL - HT 3L						CM-73	
TSR-163C		HG 3xxxR - HT 3R	1.000	1.000	5.000	1.250	1.250	CM-72	S-412
	TSL-163C	HG 3xxxL - HT 3L						CM-73	
TSR-163D		HG 3xxxR - HT 3R	1.000	1.000	6.000	1.250	1.250	CM-72	S-412
	TSL-163D	HG 3xxxL - HT 3L						CM-73	
TSR-203D		HG 3xxxR - HT 3R	1.250	1.250	6.000	1.380	1.500	CM-72	S-412
	TSL-203D	HG 3xxxL - HT 3L						CM-73	
TSR-164D		HG 4xxxR - HT 4R	1.000	1.000	6.000	1.250	1.250	CM-72	S-412
	TSL-164D	HG 4xxxL - HT 4L						CM-73	
TSR-204D		HG 4xxxR - HT 4R	1.250	1.250	6.000	1.500	1.500	CM-72	S-412
	TSL-204D	HG 4xxxL - HT 4L						CM-73	
TSR-244D		HG 4xxxR - HT 4R	1.500	1.500	6.000	1.500	2.000	CM-72	S-412
	TSL-244D	HG 4xxxL - HT 4L						CM-73	

Call for Availability

Notch Style 90° Face Grooving & ID Threading-Grooving Holders

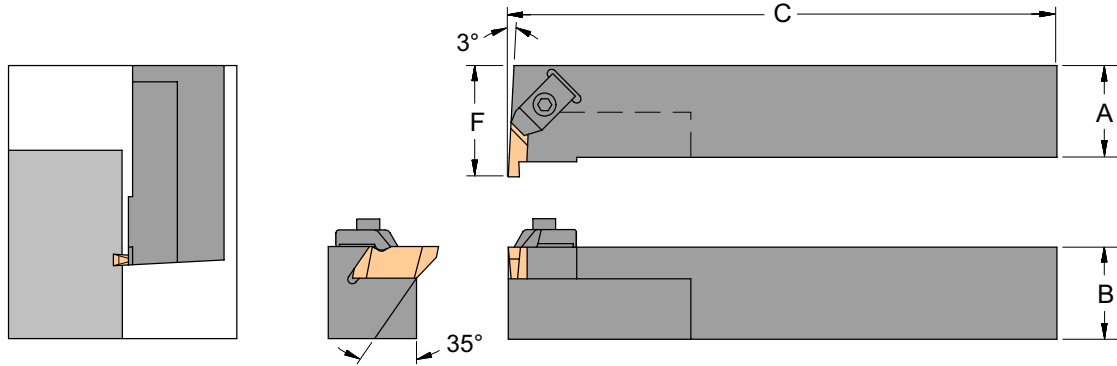

Right Hand Shown - Use Left Hand Inserts In 90° Right Hand Face Grooving Holders

Holder Description		Dimensions					Parts	
Right Hand	Left Hand	Insert Size Face - ID Grooving	A	B	C	F	Clamp	Screw
TER 163D		HF / HG 3xxxL	1.000	1.000	6.000	1.250	CM-73	S-412
	TEL 163D	HF / HG 3xxxR					CM-72	
TER 164D		HF / HG 4xxxL	1.000	1.000	6.000	1.250	CM-73	S-412
	TEL 164D	HF / HG 4xxxR					CM-72	

Notch Style Carbide Shank ID Threading & Grooving Bars

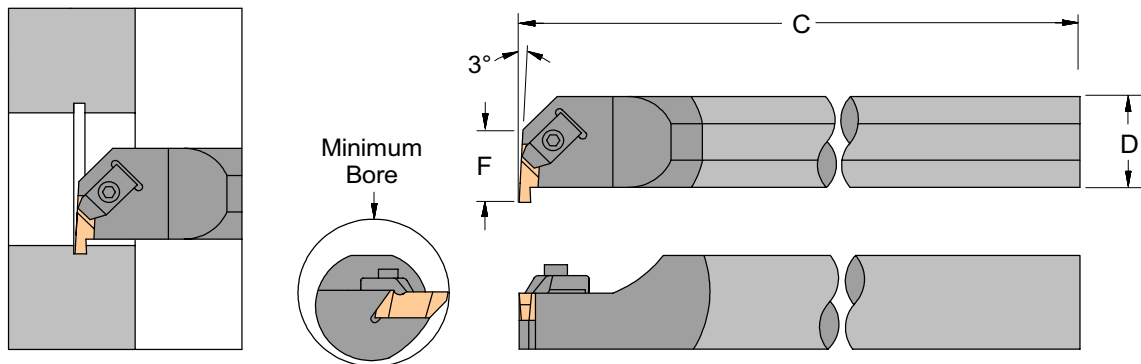

Right Hand Shown - Use Left Hand Inserts In Right Hand Boring Bars

Bar Description		Dimensions					Parts	
Right Hand	Left Hand	Insert Size Grooving - Threading	D	Min Bore	C	F	Clamp	Screw
C08-TER2		HG 2xxxL - HT 2L	.500	0.730	6.000	.437	CM-147	S-39
	C08-TEL2	HG 2xxxR - HT 2R					CM-146	
C10-TER2		HG 2xxxL - HT 2L	.625	1.000	8.000	.500	CM-75	S-310
	C10-TEL2	HG 2xxxR - HT 2R					CM-74	
C12-TER2		HG 2xxxL - HT 2L	.750	1.125	10.000	.562	CM-75	S-310
	C12-TEL2	HG 2xxxR - HT 2R					CM-74	
C16-TER2		HG 2xxxL - HT 2L	1.000	1.375	12.000	.688	CM-75	S-310
	C16-TEL2	HG 2xxxR - HT 2R					CM-74	
C16-TER3		HG 3xxxL - HT 3L	1.000	1.375	12.000	.688	CM-73	S-412
	C16-TEL3	HG 3xxxR - HT 3R					CM-72	

Call for Availability

### Notch Style Steel ID Threading & Grooving Bars With Through Coolant Holes

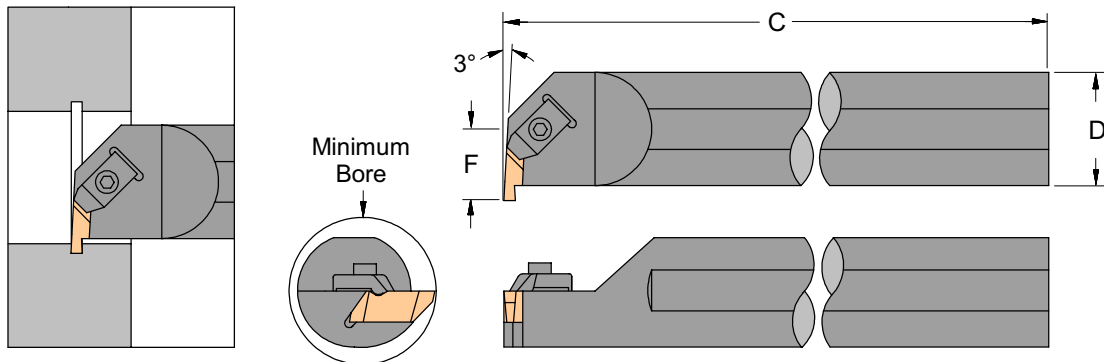

Right Hand Shown - Use Left Hand Inserts In Right Hand Boring Bars

\* Please Note: Minimum Bore Diameter for Horizon Size 2 Deep Grooving Inserts

Bar Description		Dimensions						Parts	
Right Hand	Left Hand	Insert Size Grooving - Threading	D	Min Bore	Min Bore Deep *	C	F	Clamp	Screw
A08-TER2		HG 2xxxL - HT 2L	.500	.730	1.075	6.000	.437	CM-147	S-39
	A08-TEL2	HG 2xxxR - HT 2R						CM-146	
A10-TER2		HG 2xxxL - HT 2L	.625	1.000	1.200	8.000	.500	CM-75	S-310
	A10-TEL2	HG 2xxxR - HT 2R						CM-74	
A12-TER2		HG 2xxxL - HT 2L	.750	1.125	1.325	10.000	.562	CM-75	S-310
	A12-TEL2	HG 2xxxR - HT 2R						CM-74	
A16-TER2		HG 2xxxL - HT 2L	1.000	1.375	1.575	12.000	.688	CM-75	S-310
	A16-TEL2	HG 2xxxR - HT 2R						CM-74	
A16-TER3		HG 3xxxL - HT 3L	1.000	1.375		12.000	.688	CM-73	S-412
	A16-TEL3	HG 3xxxR - HT 3R						CM-72	
A20-TER3		HG 3xxxL - HT 3L	1.250	1.750		14.000	.875	CM-73	S-412
	A20-TEL3	HG 3xxxR - HT 3R						CM-72	
A24-TER3		HG 3xxxL - HT 3L	1.500	2.000		14.000	1.000	CM-73	S-412
	A24-TEL3	HG 3xxxR - HT 3R						CM-72	
A28-TER3		HG 3xxxL - HT 3L	1.750	2.250		14.000	1.125	CM-73	S-412
	A28-TEL3	HG 3xxxR - HT 3R						CM-72	
A32-TER3		HG 3xxxL - HT 3L	2.000	2.500		14.000	1.250	CM-73	S-412
	A32-TEL3	HG 3xxxR - HT 3R						CM-72	

**NOTE: These Boring Bars come with Through Coolant Holes**  
 Boring Bars without Coolant Holes are available in some sizes. Please call for Availability.